

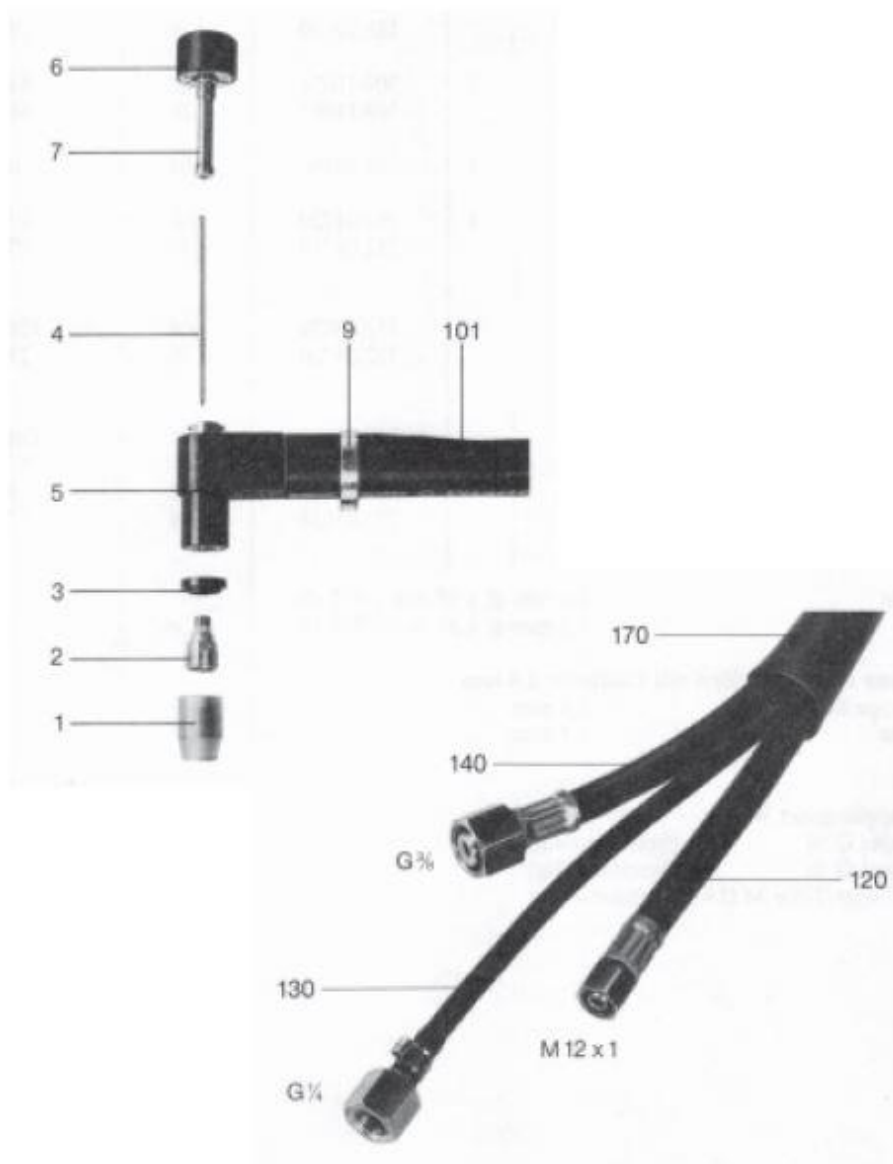

## Machine Torch TIG 2 / TIG 2S, water cooled

### Technical data according to EN 60 974-7

Rating:	320A DC
	190A AC
Duty cycle:	@100%
Tungsten electrodes:	Ø2,4 – 3,2mm





## Part Number for complete Welding Torch

Part No.

TIG 2 / 400mm	75204675
TIG 2S / 4m Single Connection	75204681
TIG 2S / 8m Single Connection	75204681S4

## Spare Part List

Pos.	Part No.	Description	Pos.	Part No.	Description
1	1202406	Ceramic Gas Nozzle Gr. 6	170	0550305	Cover Hose 25x1,5mm Neoprene (per meter)
	1202407	Ceramic Gas Nozzle Gr. 7		40291009	Hose Nipple G 3/8
2	70911071	Collet Body with Gas Lens 2,4mm		45101419	Hose Nipple G ¼
	70911081	Collet Body with Gas Lens 3,2mm		75201835	Power-Water-Grommet M12x1
3	18810190	Insulator			
4	75204720	Electrode WT 10 – 2,4mm (85mm)			
	75204719	Electrode WT 10 – 3,2mm (85mm)			
5	75204660	Torch Body TIG 2			
	75204669	Torch Body TIG 2S			
6	75204624	Snap-On-Head cpl. 2,4mm			
	75204708	Snap-On-Head cpl. 3,2mm			
7	75204651	Nut for 2,4mm and 3,2mm			
8	0543381	Hose Clamp			
101	75204742	TIG 2, Cable water cooled (2 pieces)			
	75204741	TIG 2, Schielding Gas Hose			
101	75204716	TIG 2S, Cable Assembly 4m			
	75204716S1	TIG 2S, Cable Assembly 8m			
120	70106440	Cable water cooled 4m			
	70106480	Cable water cooled 8m			
130	75204715	Schielding Gas Hose 4m			
	75204715S	Schielding Gas Hose 8m			
140	70105302	Water Inlet Hose 4m			
	70106302	Water Inlet Hose 8m			