

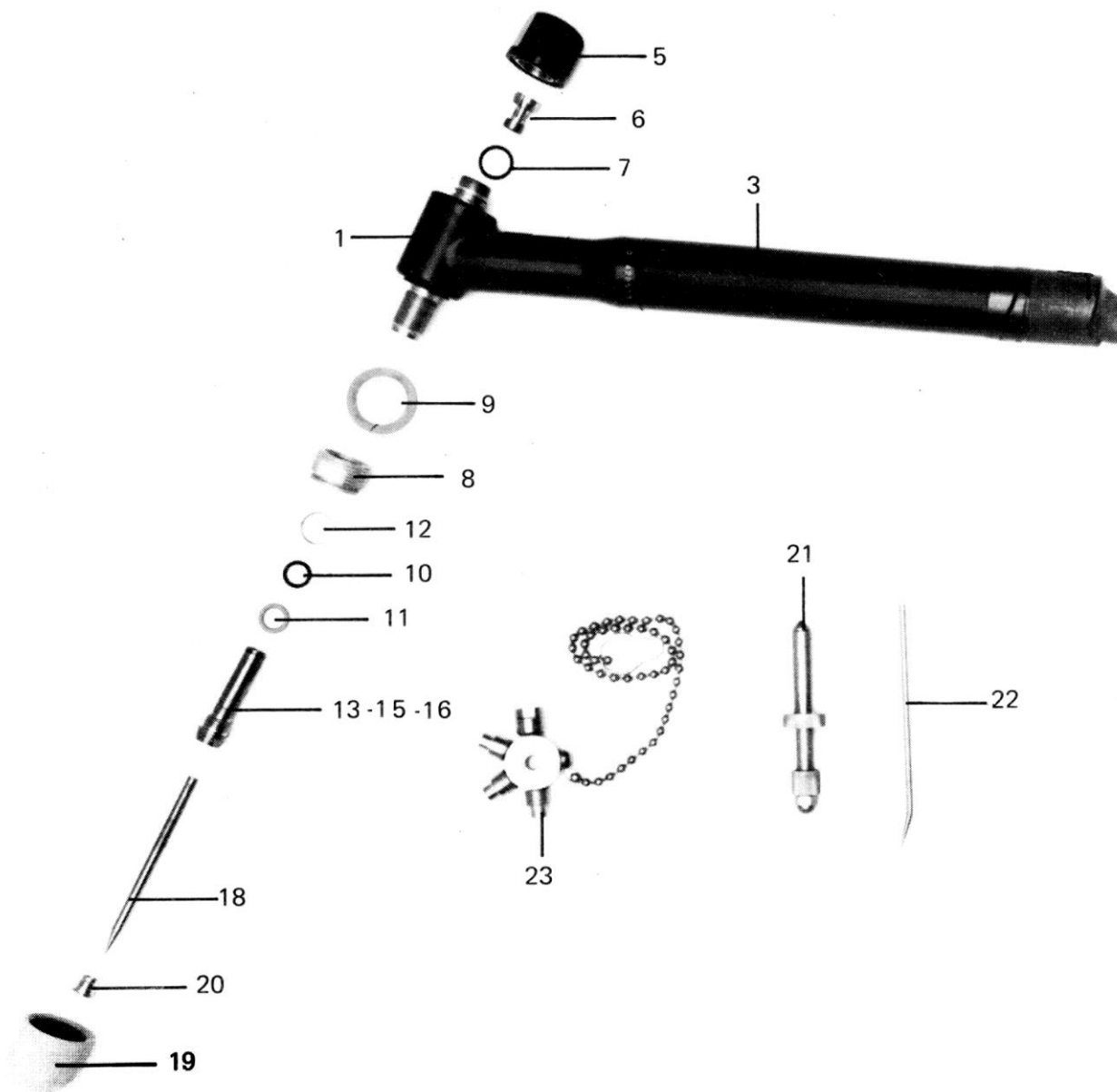

Welding Torch LPB100/220, water cooled

Technical data according to EN 60 974-7

Rating:	220A DC 100A AC
Duty cycle:	@ 60%
Plasma ga:	Argon
Shielding gas:	Argon, Argon/Hydrogen, Helium





Part Number for complete Welding Torch

Part No.	4m
Manual-Welding Torch	75301417

Spare Part List

Pos.	Part No.	Description	Pos.	Part No.	Description
1	75301433	Torch Body	20	75301523	Welding Nozzle, short - Pole 50 A 1,2 mm
	75301433M	Torch Body straight		75301524	Welding Nozzle, short - Pole 70 A 1,6 mm
3	75303040	Handle		75301525	Welding Nozzle, short - Pole 140 A 2,4 mm
5	75301450	Back Cap, short		75301526	Welding Nozzle, short - Pole 190 A 3,2 mm
	75301449	Back Cap, long		75301527	Welding Nozzle, long - Pole 40 A 1,2 mm
6	75301448	Center Piece positive and negative pole		75301528	Welding Nozzle, long - Pole 70 A 1,6 mm
7	75301521	O-Ring		75301529	Welding Nozzle, long - Pole 110 A 2,4 mm
8	75301447	Gas Diffusor		75301530	Welding Nozzle, long - Pole 180 A 3,2 mm
9	75301520	Sealing Ring		75301437	Welding Nozzle, short + Pole 50 A 1,6 mm
10	75301519	O-Ring (black)		75301438	Welding Nozzle, short + Pole 75 A 2,4 mm
11	75301518	O-Ring (red)		75301439	Welding Nozzle, short + Pole 100 A 3,2 mm
12	75301446	Locking Ring		75301440	Welding Nozzle, long + Pole 40 A 1,6 mm
13	75301517	Liner with center piece Negative Pole		75301441	Welding Nozzle, long + Pole 60 A 2,4 mm
15	75301444	Liner (without Center Piece)		75301442	Welding Nozzle, long + Pole 70 A 3,2 mm
16	75301522	Center Piece negative and positive pole	21	75301545	Tool to insert O-Ring
18	75301541	Electrode, short, negative pole	22	75301747	Tool to remove the O-Ring
	75301543	Electrode, long, negative pole	23	75301451	Gauge
	75301542	Electrode, short, positive pole		75301628	Connection 9/16 - 18 UNF/G 1/8 (2 pcs) Uniwig G200P
	75303795	Electrode, long, positive pole		75301629	Connection 9/16 - 18 UNF/G 1/4 (2 pcs) Uniwig G200P
19	75301436	Gas Nozzle		75303051	Reduction 9/16 - 18 UNF/G 3/8
	75303037	Gas nozzle with gas lense		75303052	Reduction 9/16 - 18 UNF/M 12 x 1
				75105105	Silicon, 5g